

Since 1898
CONSEW®

CONSOLIDATED SEWING MACHINE CORP.

└ INDUSTRIAL SEWING & CUTTING EQUIPMENT

255RB-3D

339RB-3D

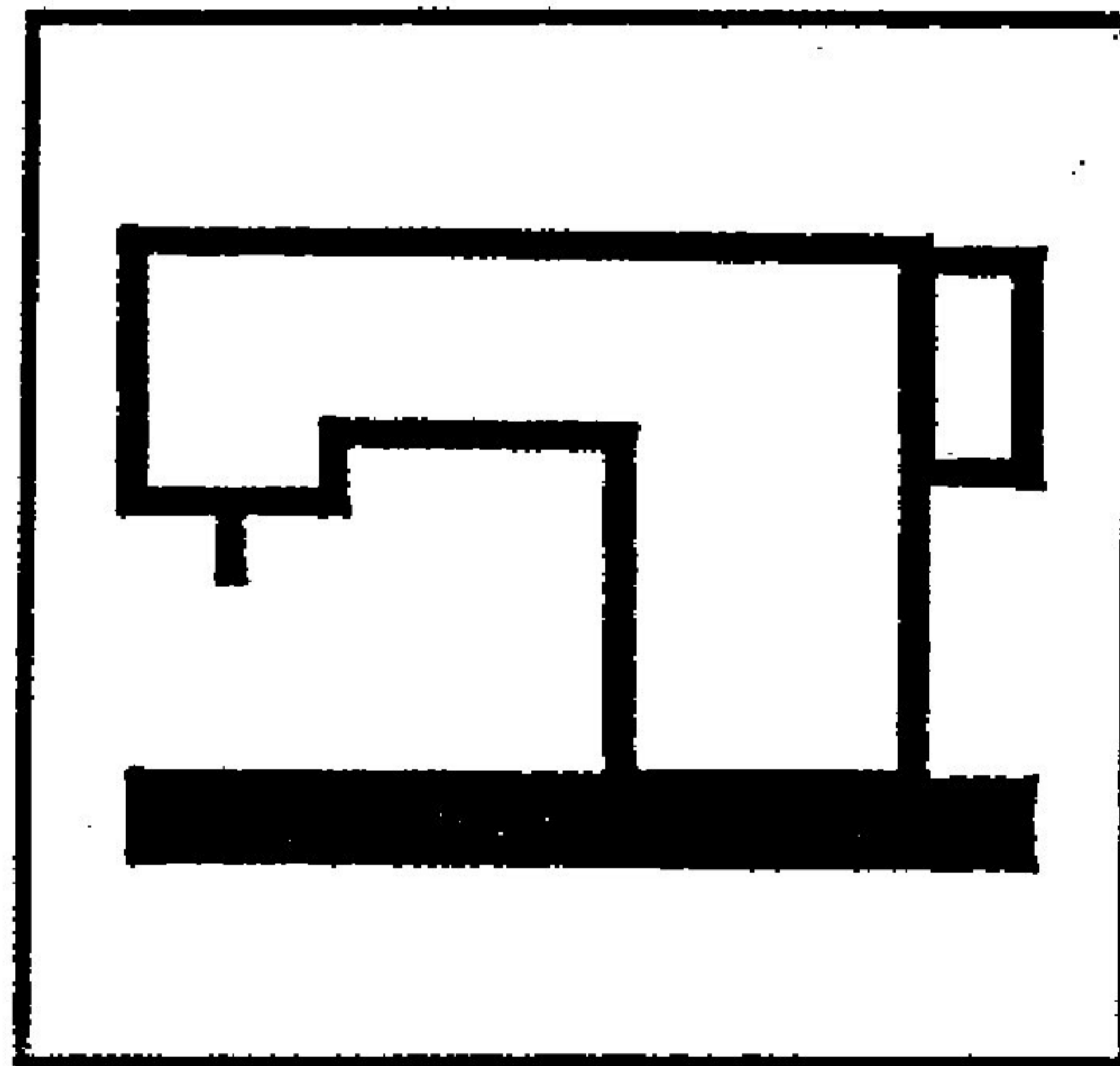

PARTS LIST

FACE PLATE, ARM TOP COVER

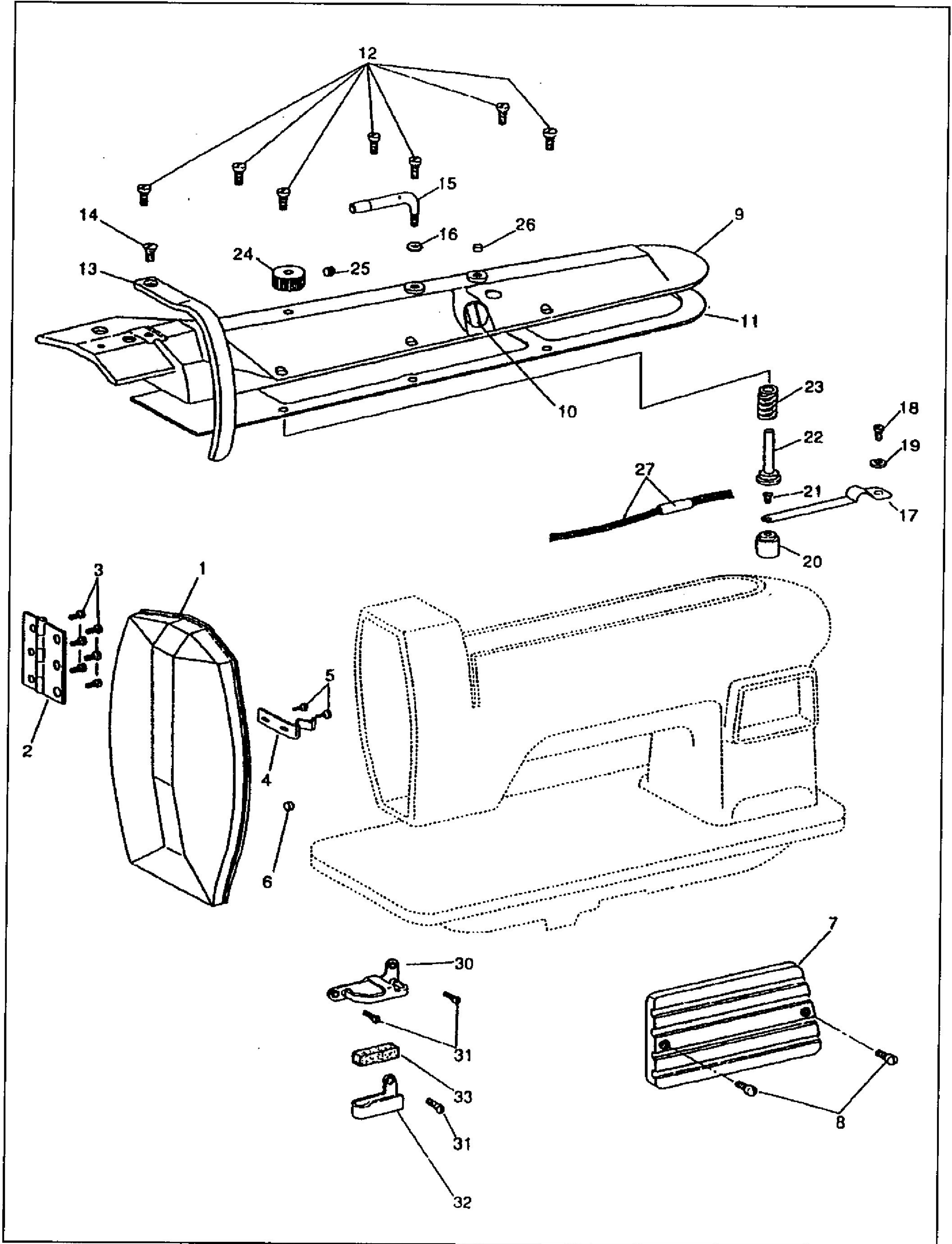

FACE PLATE, ARM TOP COVER

NO	PART NO	255RB-3D	339RB-3D	PARTS NAME
1	15035	1	1	FACE PLATE
2	15036	1	1	HINGE
3	15039	6	6	SCREW 1/8×44 L=3.5
4	15037	1	1	FACE PLATE SPRING
5	15039	2	2	SCREW 1/8×44 L=3.5
6	15038	1	1	RUBBER
7	13556	1	1	ARM TOP COVER
8	8040	3	3	SCREW 9/64×40 L=8.0
9	15003	1	1	ARM TOP COVER
10	11007	1	1	OIL LEVER INDICATOR
11	15004	1	1	GASKET
12	15007	7	7	SCREW 9/64×40 L=10.0
13	36708	1	1	THREAD TAKE UP COVER
14	6031-02	1	1	SCREW 11/64×40 L=9.0
15	11006	1	2	ARM TOP COVER THREAD GUIDE
16	13076-02	1	2	NUT 7/32×32
17	15086	1	1	OIL CONTROL SPRING
18				
19	11142	1	1	WASHER
20	11004	1	1	OIL REGULATOR
21	10597	1	1	SCREW 1/8×40 L=3.3
22	15058	1	1	OIL REGULATING STUD
23	15059	1	1	OIL REGULATING SPRING
24	15057	1	1	OIL REGULATING DIAL
25	8009	1	1	SET SCREW 15/64×28 L=7.5
26	15038	1		RUBBER
27	15034C	1	1	OIL TUBE AND OIL WICK COMPLETE
28				
29				
30	15054	1	1	THREAD GUIDE (UPPER)
31	10685	3	3	SCREW 3.4×36 L=6.5
32	10759-A	1	1	THREAD GUIDE (LOWER)
33	10760	1	1	FELT

TAKE UP LEVER, ARM SHAFT, MACHINE PULLEY

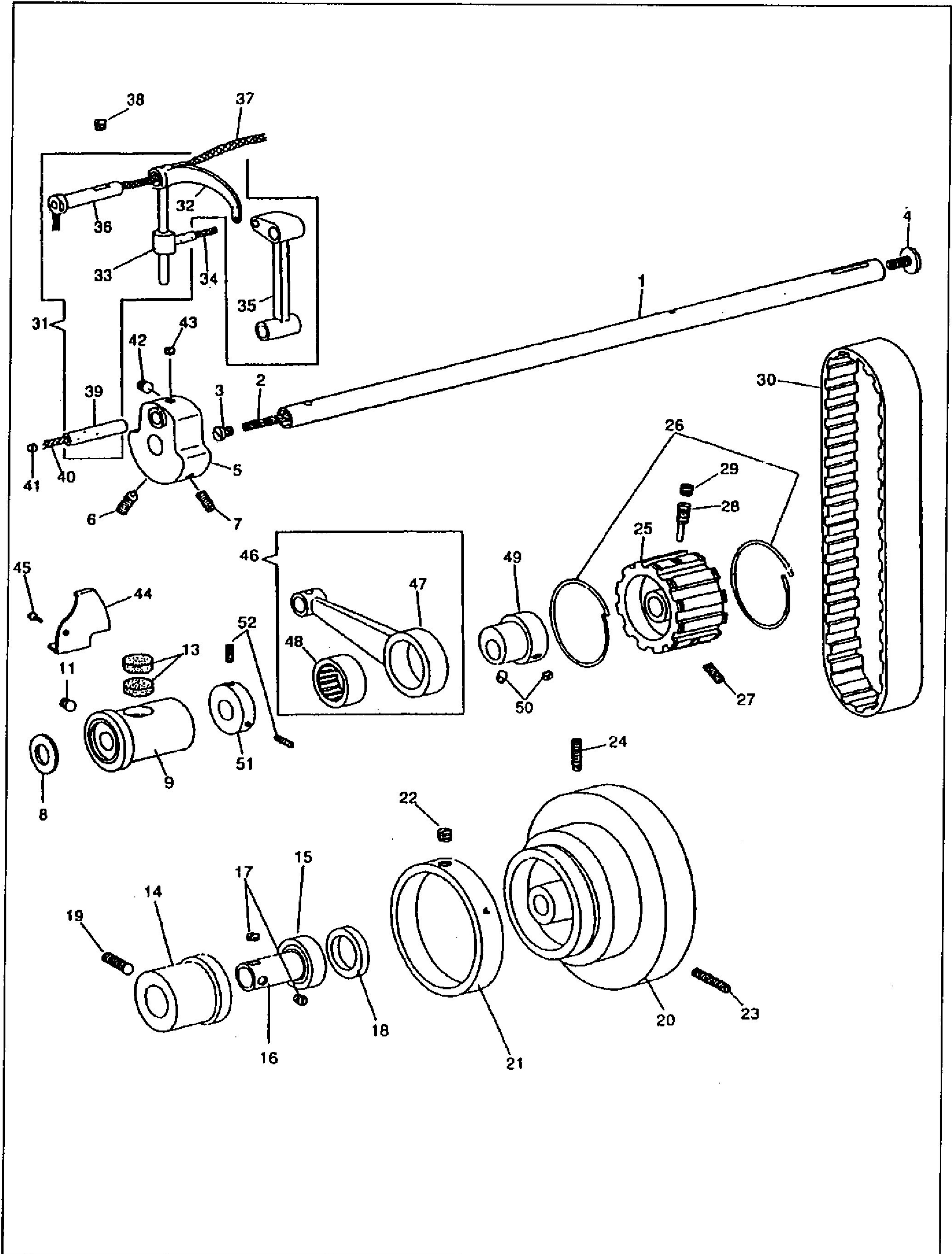

TAKE UP LEVER , ARM SHAFT , MACHINE PULLEY

NO	PART NO	255RB-3D	339RB-3D	PARTS NAME
1	15209	1	1	ARM SHAFT
2	15033	1	1	OIL WICK
3	10506	1	1	OIL STOP SCREW 7.85×20 L=6.0
4	10577	1	1	PULLEY ADJUSTING SCREW 6.75×24 L=11.0
5	19414	1	1	NEEDLE BAR CRANK
6	19415	1	1	POSITION SCREW 1/4×28 L=20.0
7	19416	1	1	SET SCREW 1/4×28 L=14.0
8	10563	1	1	WASHER
9	10562	1	1	ARM SHAFT BUSHING (LEFT)
11	10524	1	1	SET SCREW 6.75×24 L=6.5
13	10725	2	2	OIL FELT
14	13074	1	1	ARM SHAFT BALL BEARING ADAPTOR
15	10567	1	1	ARM SHAFT BALL BEARING
16	13361	1	1	ARM SHAFT BALL BEARING ADAPTOR SLEEVE
17	19418	2	2	SET SCREW 1/4×28 L=4.5
18	10568	1	1	BALL BEARING RETAINING RING
19	10571	1	1	SCREW 6.75×24 L=20.0
20	10504	1	1	MACHINE PULLEY
21	10943	1	1	FEED INDICATING (W/O BELT GUARD)
22	10566	1	1	SET SCREW 1/4×32 L=5.5
23	10576	1	1	POSITION SCREW 15/64×28 L=21.0
24	10579	1	1	SET SCREW 15/64×28 L=20.0
25	10569	1	1	ARM SHAFT CONNECTING BELT PULLEY
26	10574	2	2	BELT PULLEY SPRING FLANGE
27	10571-G	1	1	SET SCREW 6.75×24 L=20.0
28	10570	1	1	POSITION SCREW 6.75×24 L=14.5
29	10524-G	1	1	POSITION SCREW SET SCREW 6.75×24 L=6.5
30	10621	1	1	ARM SHAFT CONNECTING BELT
31	15024C	1	1	THREAD TAKE UP LEVER COMPLETE
32	15024	1	1	THREAD TAKE UP LEVER
33	15026	1	1	THREAD TAKE UP LEVER DRIVING STUD
34	10728	1	1	OIL WICK
35	10528	1	1	NEEDLE BAR CONNECTING LINK
36	15013	1	1	THREAD TAKE UP LEVER HINGE STUD
37	11042	1	1	OIL WICK
38	10524	1	1	SET SCREW 6.75×24 L=6.5
39	10523	1	1	NEEDLE BAR CONNECTING LINK STUD
40	10726	1	1	OIL WICK
41	15038	1	1	RUBBER OIL STOPPER
42	19417	1	1	SCREW 1/4×28 L=6.5
43	19418	1	1	SCREW 1/4×28 L=4.5
44	10551	1	1	THREAD TAKE UP LEVER OIL GUARD
45	10650	1	1	SCREW 3.4×36 L=6.0
46	10772C	1	1	LIFTING ECCENTRIC CONNECTING COMPLETE
47	10772	1	1	LIFTING ECCENTRIC CONNECTION
48	10773	1	1	NEEDLE BEARING
49	19427	1	1	LIFTING ECCENTRIC
50	19508	2	2	SET SCREW 1/4×40 L=5.5
51	11879	1	1	LIFTING ECCENTRIC COLLAR
52	10573	2	2	SET SCREW 7/32×32 L=11.0

PRESSER BAR, VIBRATING PRESSER BAR

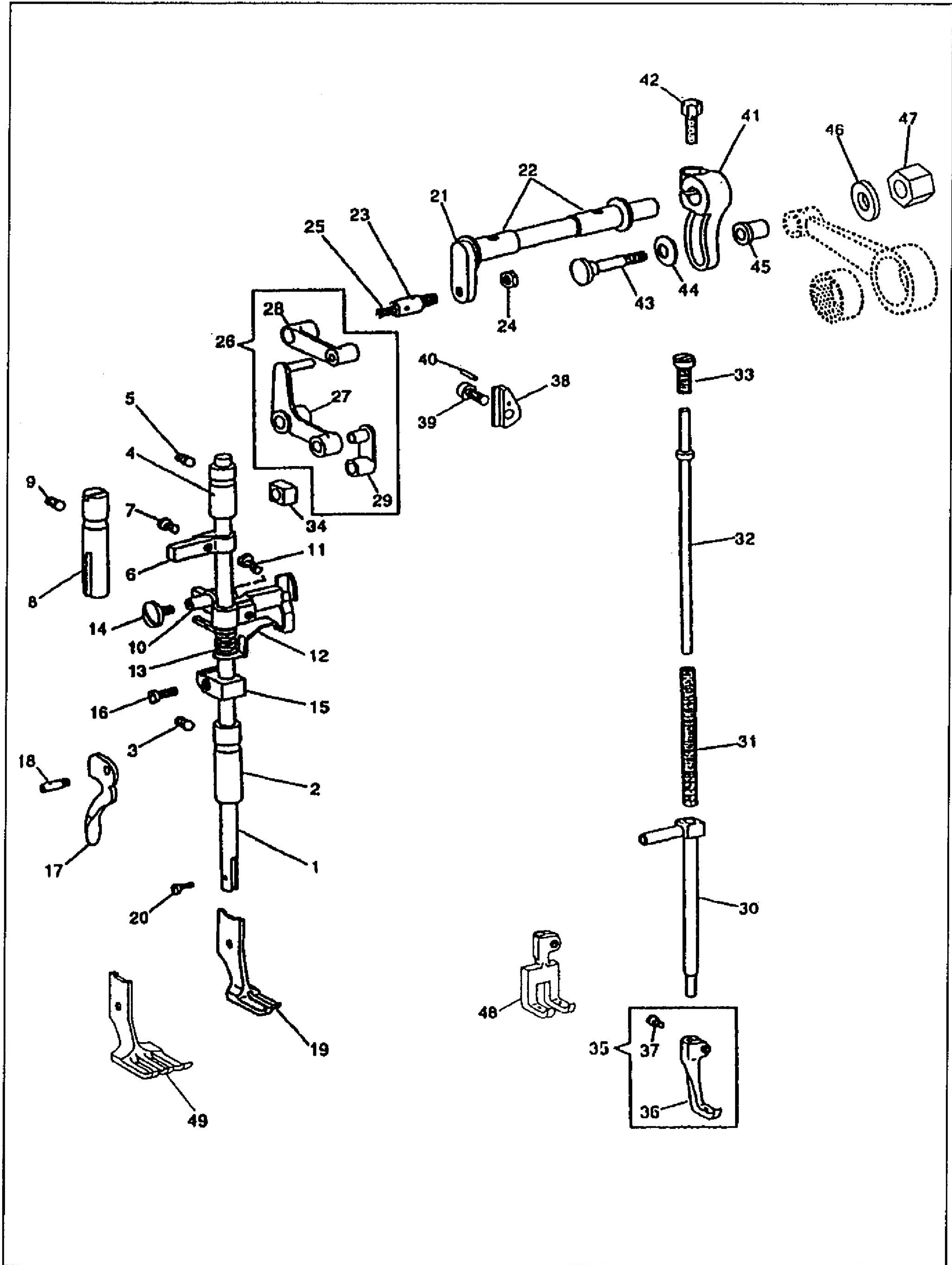

PRESSER BAR, VIBRATING PRESSER BAR

NO	PART NO	255RB-3D	339RB-3D	PARTS NAME
1	10540	1	1	PRESSER BAR
2	10539-A	1	1	PRESSER BAR BUSHING (LOWER)
3	10761	1	1	SET SCREW 6.75×24 L=11.0
4	10538	1	1	PRESSER BAR BUSHING (UPPER)
5	10761	1	1	SET SCREW 6.75×24 L=11.0
6	10541	1	1	PRESSER BAR POSITION GUIDE BRACKET
7	10662	1	1	SCREW 5/32×40 L=6.5
8	10543	1	1	PRESSER BAR POSITION GUIDE
9	10761	1	1	SET SCREW 6.75×24 L=11.0
10	18479	1	1	PRESSER BAR LIFTING BRACKET
11	19518	1	1	SCREW 11/64×40 L=14.0
12	10546-A	1	1	TENSION RELEASE SLIDE
13	10547	1	1	TENSION RELEASE SPRING
14	18480	1	1	LIFTING BELL CRANK SCREW 11/64×40 L=8.0
15	13360	1	1	PRESSER BAR SPRING BARCKET
16	13365	1	1	PINCH SCREW M4X0.7 L=9.0
17	10659	1	1	PRESSER BAR LIFTER
18	10660	1	1	HINGE SCREW 4.5×32
19	10796	1		LIFTING PRESSER FOOT
20	10664	1	1	SCREW 3.4×36 L=9.0
21	19425	1	1	LIFTING ROCK SHAFT
22	10514	2	2	LIFTING ROCK SHAFT BASHING
23	16709	1	1	SCREW 1/4×28
24	19516	1	1	NUT 1/4×28
25	10728	1	1	OIL WICK
26	10558C	1	1	LIFTING BELL CRANK COMPLETE
27	10558	1	1	LIFTING BELL CRANK
28	10557	1	1	LIFTING BELL CRANK LINK
29	10556	1	1	VIBRATING PRESSER BAR CONNECTING LINK
30	34713	1	1	VIBRATING PRESSER BAR
31	10554	1	1	VIBRATING PRESSER BAR EXTENSION SPRING
32	10553-A	1	1	VIBRATING PRESSER BAR EXTENSION
33	15060	1	1	SCREW 5/16×24 L=16.0
34	15118	1	1	VIBRATING PRESSER BAR SLIDE BLOCK
35	19411C	1		VIBRATING PRESSER FOOT COMPLETE
36	19411	1		VIBRATING PRESSER FOOT
37	17104	1	1	PINCH SCREW 11/64×40 L=6.0
38	10548-A	1	1	LIFTING BRACKET GUIDE BLOCK
39	10519	1	1	PINCH SCREW 6.75X24 L=17.5
40	15111	1	1	PIN
41	19419	1	1	LIFTING ECCENTRIC CONNECTING CRANK
42	19420	1	1	PINCH SCREW 1/4×28 L=16.0
43	10775	1	1	HINGE SCREW 7/32×32
44	10703	1	1	WASHER
45	10774	1	1	LIFTING ECCENTRIC CONNECTION COLLAR
46	H4728H8001	1	1	WASHER
47	H3100F2160	1	1	NUT 7/32×32
48	H4807F8001		1	VIBRATING PRESSER FOOT
49	H4757E8001		1	LIFTING PRESSER FOOT

NEEDLE BAR ROCK FRAME , ROCK SHAFT CRANK CONNECTION

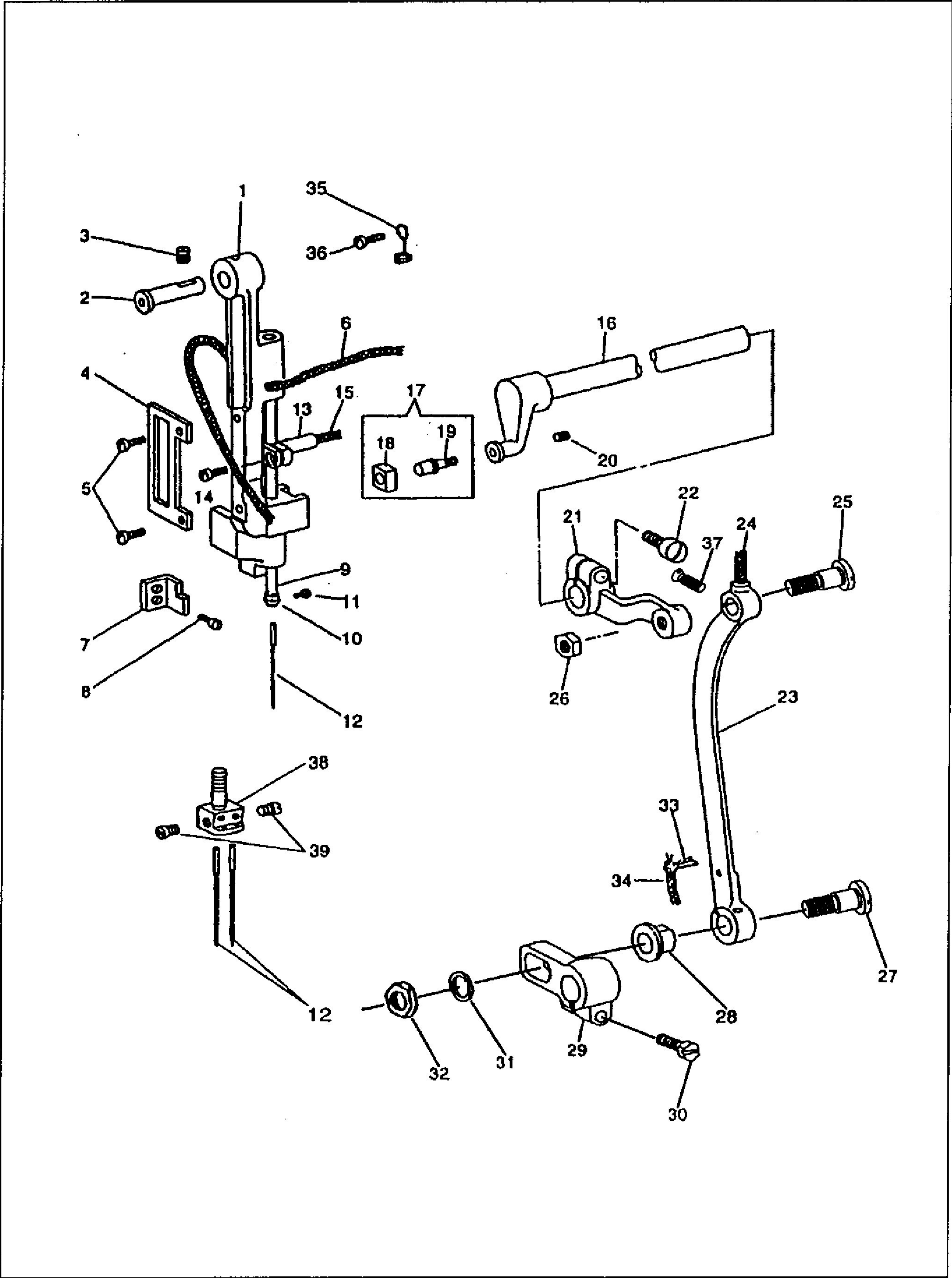

NEEDLE BAR ROCK FRAME , ROCK SHAFT CRANK CONNECTION

NO	PART NO	255RB-3D	339RB-3D	PARTS NAME
1	15110-A	1	1	NEEDLE BAR ROCK FRAME
2	11875	1	1	HINGE STUD
3	10525	1	1	SET SCREW 6.75×24 L=9.0
4	15117	1	1	SLIDE BLOCK PLATE
5	8100	2	2	SCREW 9/64×40 L=6.5
6	15031	1	1	OIL WICK
7	10560	1	1	NEEDLE BAR ROCK FRAME POSITION BRACKET
8	10561	1	1	LIFTING BRACKET GUIDE SCREW 11/64×32 L=6.5
9	HE205G8001	1		NEEDLE BAR
9	H4724F8001		1	NEEDLE BAR
10	15089	1		THREAD GUIDE
11	B140553	1		SCREW 1/8×40 L=4.5
12	NO122	1	2	NEEDLE
13	19426	1	1	NEEDLE BAR CONNECTING STUD
14	13365	1	1	PINCH SCREW M4×0.7 L=9.0
15	10726	1	1	OIL WICK
16	10578	1	1	NEEDLE BAR ROCK FRAME ROCK SHAFT
17	11876C	1	1	SLEDE BLOCK COMPLETE
18	11877	1	1	SLIDE BLOCK
19	11876	1	1	SLIDE BLOBK STUD
20	10581	1	1	SET SCREW 7/32×32 L=7.0
21	15016	1	1	ROCK SHAFT CRANK
22	10519	1	1	PINCH SCREW 6.75×24 L=17.5
23	HE606E8001	1	1	ROCK SHIFT CRANK CONNECTION
24	10728	1	1	OIL WICK
25	HE608E8001	1	1	SCREW 9/32×28 L=23.5
26	8105	1	1	NUT 9/32×28
27	HE609E8001	1	1	SCREW 5/16×28 L=29.5
28	HE610E8001	1	1	NEEDLE BAR ROCK FRAME REGULATING PIPE
29	15019	1	1	FEED ROCK SHAFT CRANK
30	10754	1	1	PINCH SCREW 6.75×24 L=16
31		1	1	WASHER
32		1	1	NUT 5/16×28
33	10779	1	1	CLIP
34	10778	1	1	OLK WICK
35	4221	1	1	OLK WICK ETAINER
36	15007	1	1	SCREW 9/64×40 L=10.0
37		2	2	SCREW 9/64×40 L=12.0

KNEE LIFTER LIFTING LEVER, PRESSER BAR SPRING

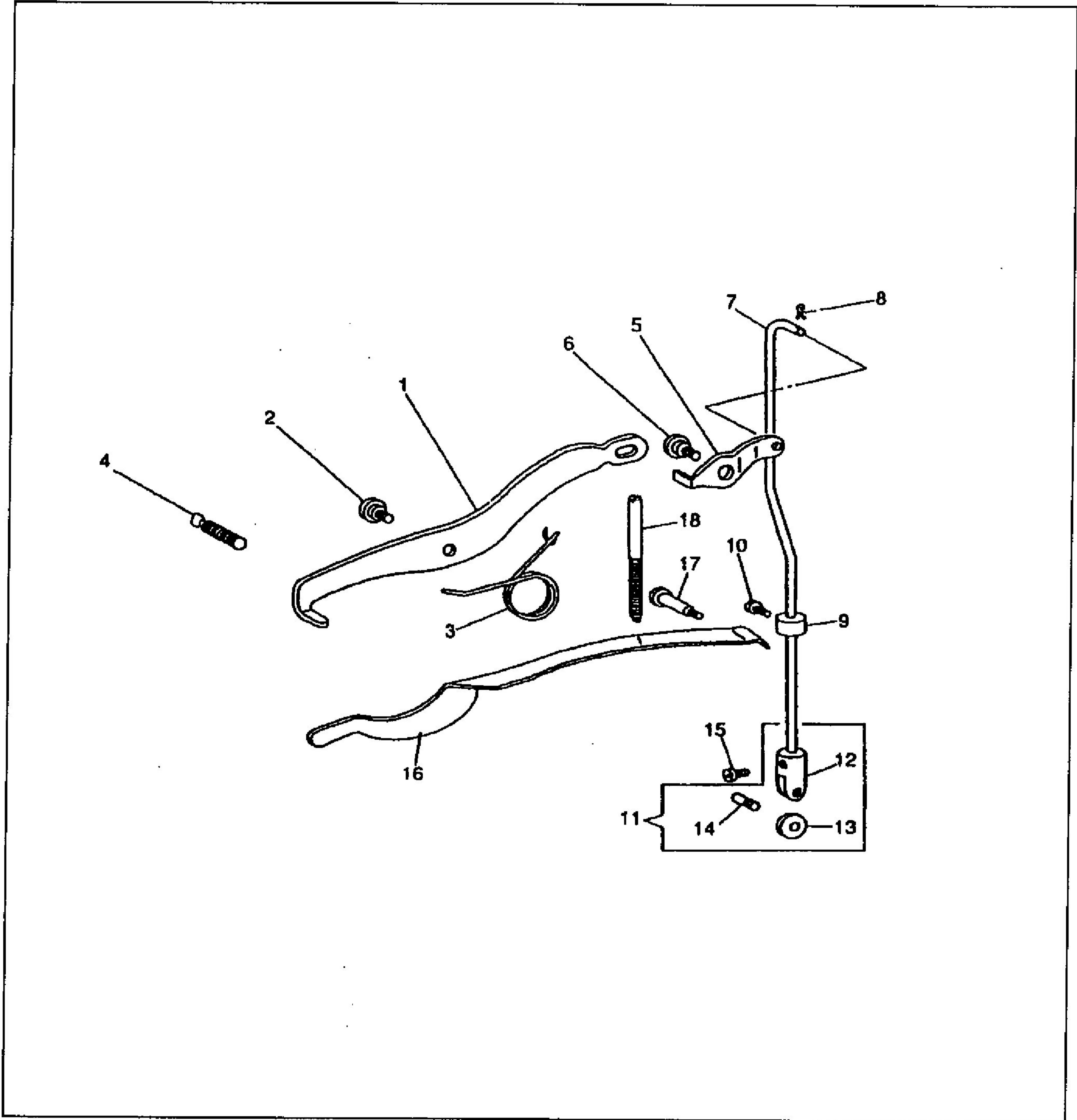

KNEE LIFTER LIFTING LEVER, PRESSER BAR SPRING

NO	PART NO	255RB-3D	339RB-3D	PARTS NAME
1	10710	1	1	KNEE LIFTER LIFTING LEVER
2	10712	1	1	HINGE SCREW 6.75X24
3	13059	1	1	SPRING
4	11154	1	1	SCREW 6.75×24
5	10711	1	1	KNEE LIFTER CONNECTING LEVER
6	10712	1	1	HINGE SCREW 6.75X24
7	15075	1	1	KNEE LIFTER CONNECTING LEVER LIFTING ROD
8	15076	1	1	SET RIN
9	10714	1	1	LIFTING ROD COLLAR
10	10561	1	1	LIFTING BRACKET GUIDE SCREW 11/64×32 L=6.5
11	10717C	1	1	LIFTING ROD ROLLAR BRACKET COMPLETE
12	10717	1	1	LIFTING ROD ROLLAR BRACKET
13	10718	1	1	LIFTING ROD ROLLAR
14	10719	1	1	SCREW 3.4×36
15	10561	1	1	LIFTING BRACKET GUIDE SCREW 11/64×32 L=6.5
16	10705	1	1	PRESSER BAR SPRING (FLAT)
17	10706	1	1	PRESSER BAR SPRING SUPPORT SCREW
18	11156	1	1	PRESSER BAR SPRING REGULATING SCREW

HOOK DRIVING SHAFT, SAFETY CLUTCH PULLEY, FEED DRIVING CAM

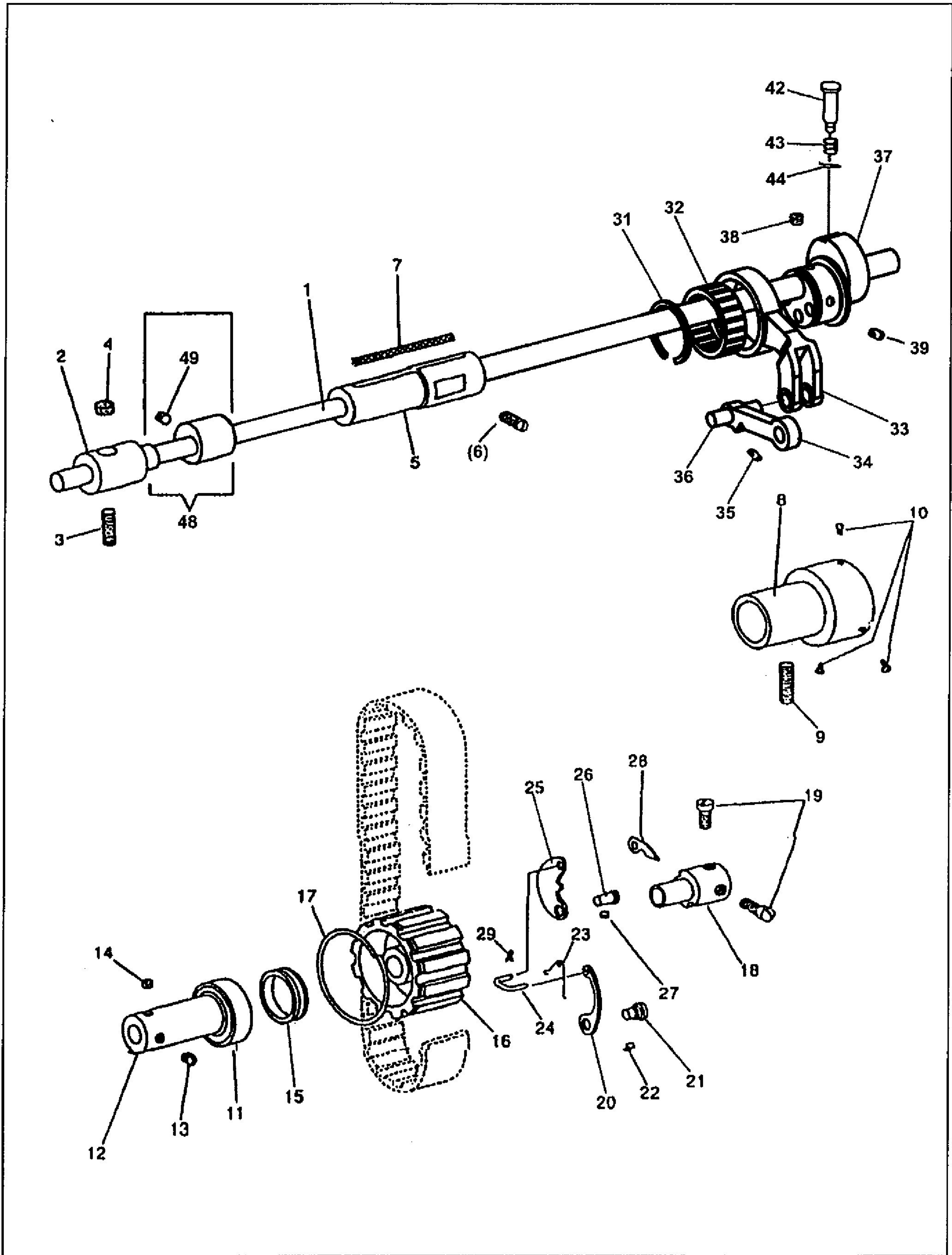

HOOK DRIVING SHAFT, SAFETY CLUTCH PULLEY, FEED DRIVING CAM

NO	PART NO	255RB-3D	339RB-3D	PARTS NAME
1	10603	1	1	HOOK DRIVING SHAFT
2	H4706H8001	1	1	HOOK DRIVING SHAFT BUSIING(FRONT)
3	10571	1	1	SET SCREW 6.75×24 L=20.0
4	11080	1	1	OILING FELT
5	H4712H8001	1	1	HOOK DRIVING SHAFT BUSIING(MIDDLE)
6	10522	2	2	SET SCREW 6.75×24 L=14.0
7	10729	1	1	OIL WICK
8	30157	1	1	HOOK DRIVING SHAFT BUSIING(BACK)
9	10571	1	1	SET SCREW 6.75×24 L=20.0
10	10609	3	3	SCREW 3.4×36 L=5.5
11	10567	1	1	BALL BEARING
12	10607	1	1	COLLAR
13	10566	1	1	SET SCREW 1/4×32 L=5.5
14	10658	1	1	POSITION SCREW 1/4×32 L=5.5
15	10608	1	1	BALL BEARING RETAINING WASHER
16	10610-01	1	1	SAFETY CLUTCH PULLEY
17	10574	1	1	PULLEY SPRING FLANGE
18	10611	1	1	SAFETY CLUTCH COLLAR
19	10612	2	2	SCREW 1/4×32 L=10.5
20	10615	1	1	SAFETY CLUTCH LOCKING LEVER SPRING
21	10614	1	1	HINGE PIN
22	10581	1	1	SCREW 7/32×32 L=7.0
23	10619	1	1	SAFE CLUTCH THROW INLATCH SPRING
24	10618	1	1	SAFE CLUTCH RATCHET CONNECTING LIN
25	10616	1	1	SAFE CLUTCH LOCKING LEVER
26	10613	1	1	HINGE STUD
27	10581	1	1	SCREW 7/32×32 L=7.0
28	10617	1	1	SAFE CLUTCH RATCHET
29	10620	1	1	SAFE CLUTCH THROW INLATCH PIN
30				
31	10723	1	1	C-TYPE STOP RING
32	10722	1	1	BEARING
33	34007	1	1	FEED CONNECTING ROD
34	34010	1	1	LINK
35	11953	1	1	SCREW 7/32×32 L=5.5
36	34011	1	1	SHAFT
37	34009	1	1	FEED ECCENTRIC
38	14114	1	1	SCREW 1/4×32 L=6.5
39	14116	1	1	SCREW 1/4×32 L=9.5
42	34008	1	1	FEED REGULATING STUD
43	10673	1	1	SPRING
44	10674	1	1	PIN
48	10637	1	1	FEED LIFTING CAM COMPLETE
49	10658	1	1	SET SCREW 1/4×32 L=5.5

THROAT PLATE, FEED BAR, FEED ROCK SHAFT

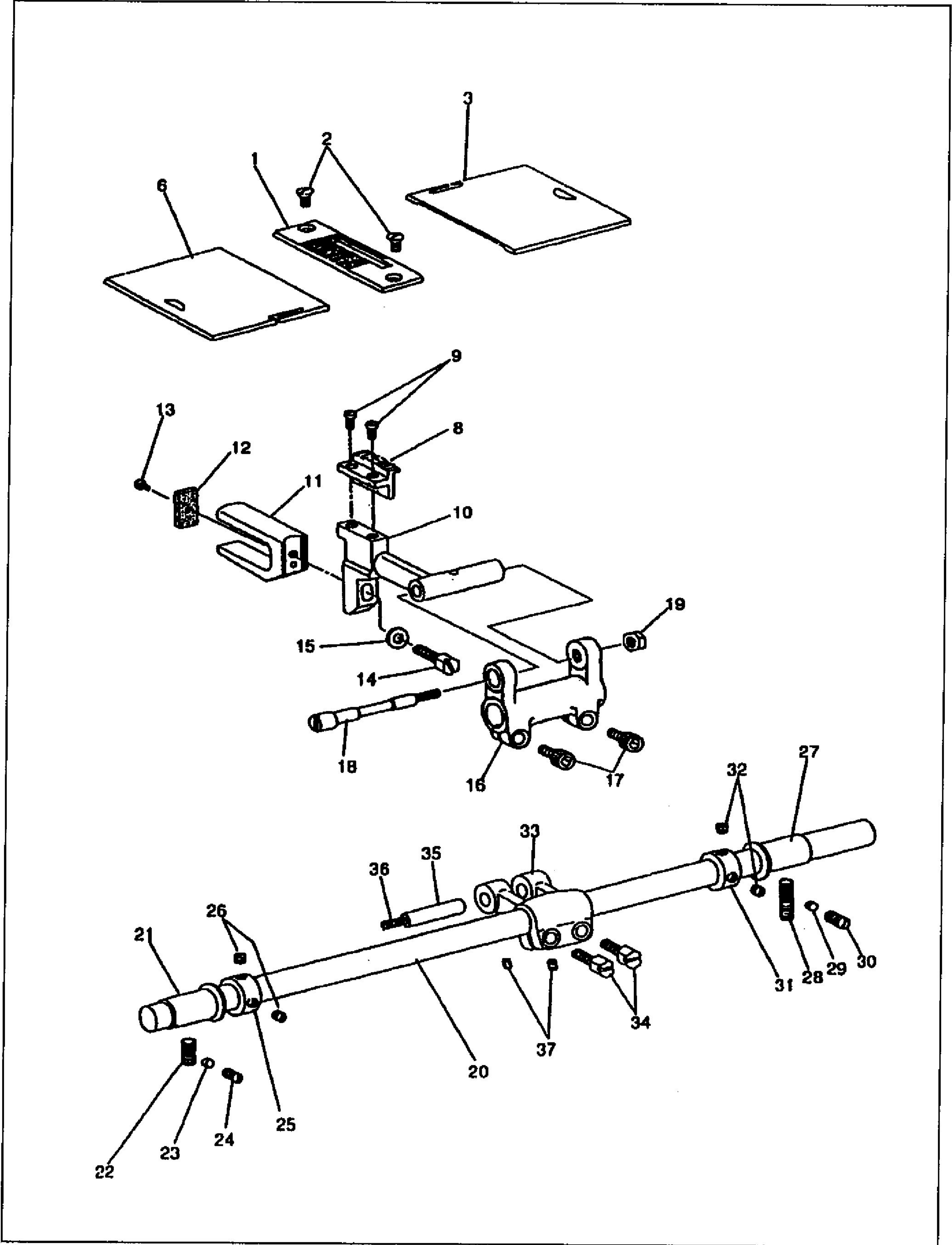

THROAT PLATE,FEED BAR,FEED ROCK SHAFT

NO	PART NO	255RB-3D	339RB-3D	PARTS NAME
1	H5014B8001	1		THROAT PLATE
1	H4917B8001		1	THROAT PLATE
2	6031-01	2	2	SCREW 11/64×40 L=9.0
3	15056	1		BED SLIDE(RIGHT)
3	H4733B8001		1	BED SLIDE(RIGHT)
4	10668	1	1	SPRING
5	10667	1	1	PIN
6	H4812B8001	1		BED SLIDE(LEFT)
6	H4732B8001		1	BED SLIDE(LEFT)
8	H4807H8001	1		FEED DOG
8	H4944H8001		1	FEED DOG
9	10601	2	2	SCREW 1/8×40 L=7.0
10	10594	1		FEED BAR
10	H4942H8001		1	FEED BAR
11	10595	1	1	FEED LIFTING CAM FORK
12	10596	1	1	OILING FELT
13	10597	1	1	SCREW 1/8×40 L=3.3
14	70129	1	1	SCREW 7/32×32 L=15.0
15	10599	1	1	WASHER
16	16704	1		FEED DRIVING ROCK FRAME
16	HH704H8001		1	FEED DRIVING ROCK FRAME
17	18065	2	2	PINCH SCREW M5×0.8 L=14.0
18	16705	1		FEED BAR HINGE PIN
18	H32243G205		1	FEED BAR HINGE PIN
19	16706	1	1	NUT 1/4×28
20	11888	1	1	FEED ROCK SHAFT
21	10588	1	1	BUSHING(FRONT)
22	10522	1	1	SCREW 6.75×24 L=14.0
23	11068	1	1	LINER
24	10761	1	1	SET SCREW 6.75×24 L=11.0
25	10593	1	1	COLLER(FRONT)
26	10764	2	2	SET SCREW 6.75×24 L=4.5
27	10763	1	1	BUSHING(BACK)
28	10571	1	1	SCREW 6.75×24 L=20.0
29	11068	1	1	LINER
30	10525	1	1	SCREW 6.75×24 L=9.0
31	10593	1	1	COLLER(BACK)
32	10764	2	2	SET SCREW 6.75×24 L=4.5
33	16708	1	1	FEED ROCK SHAFT CRANK
34	19420	2	2	PINCH SCREW 1/4×28 L=16.0
35	11962	1	1	FEED ROCK SHAFT CRANK STUD
36	11954	1	1	OIL WICK
37	11953	2	2	SET SCREW 7/32×32 L=5.5

FEED REVERSING LEVER, FEED DRIVING ECCENTRIC CONNECTION

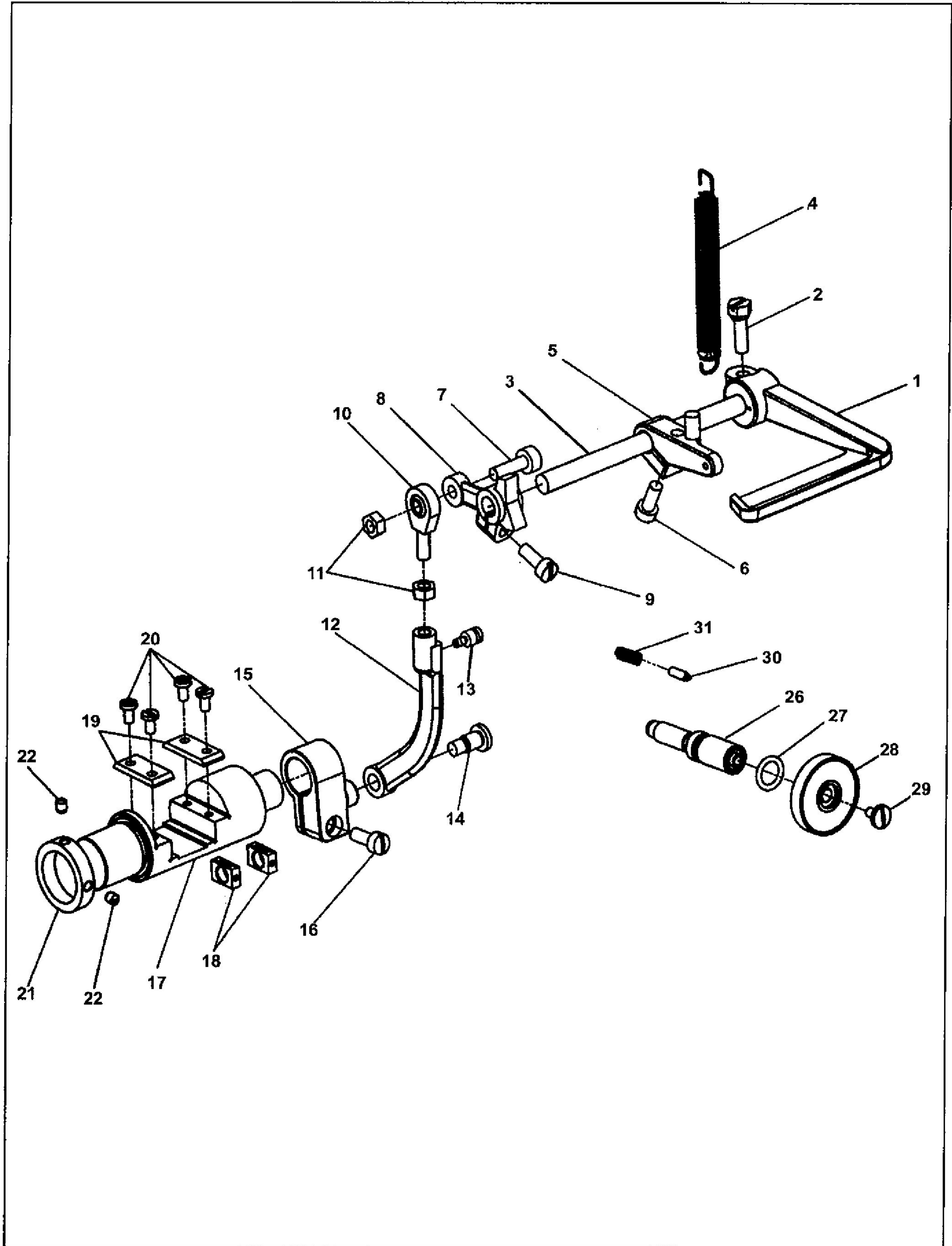

FEED REVERSING LEVER,FEED DRIVING ECCENTRIC CONNECTION

NO	PART NO	255RB-3D	339RB-3D	PARTS NAME
1	34031	1	1	FEED REVERSING LEVER
2	10845	1	1	SCREW 15/64×28 L=18.0
3	15208	1	1	FEED REVERSING LEVER SHIFT
4	34019	1	1	SPRING
5	30618	1	1	ARM
6	1365	1	1	PINCH SCREW 15/64×28 L=16.0
7	28152	1	1	SHAFT
8	34027	1	1	FEED REGULATOR CAM
9	10519	1	1	SCREW 6.75×24 L=17.5
10	11409	1	1	ROUNDNESS CONNECTER
11	11412	2	2	NUT
12	34033	1	1	LINK
13	34035	1	1	SET SCREW 9/64×40 L=15.0
14	34048	1	1	SCREW 5/16×24 L=16.0
15	34014	1	1	REVERSE SEWING CRANK
16	1365	1	1	PINCH SCREW 15/64×28 L=16.0
17	34005	1	1	REVERSE BLOCK
18	34012	2	2	SQUARE BLOCK
19	34013	2	2	GUIDE PLATE
20	15055	4	4	SCREW 11/64×40 L=8.0
21	34006	1	1	COLLAR
22	11953	2	2	SET SCREW 7/32×32 L=5.5
26	34028	1	1	SCREW BAR
27	18420	1	1	O-RING
28	34029	1	1	DIAL
29	18417	1	1	SCREW 11/64×32 L=8.0
30	18418	1	1	PIN
31	15729	1	1	SRRING

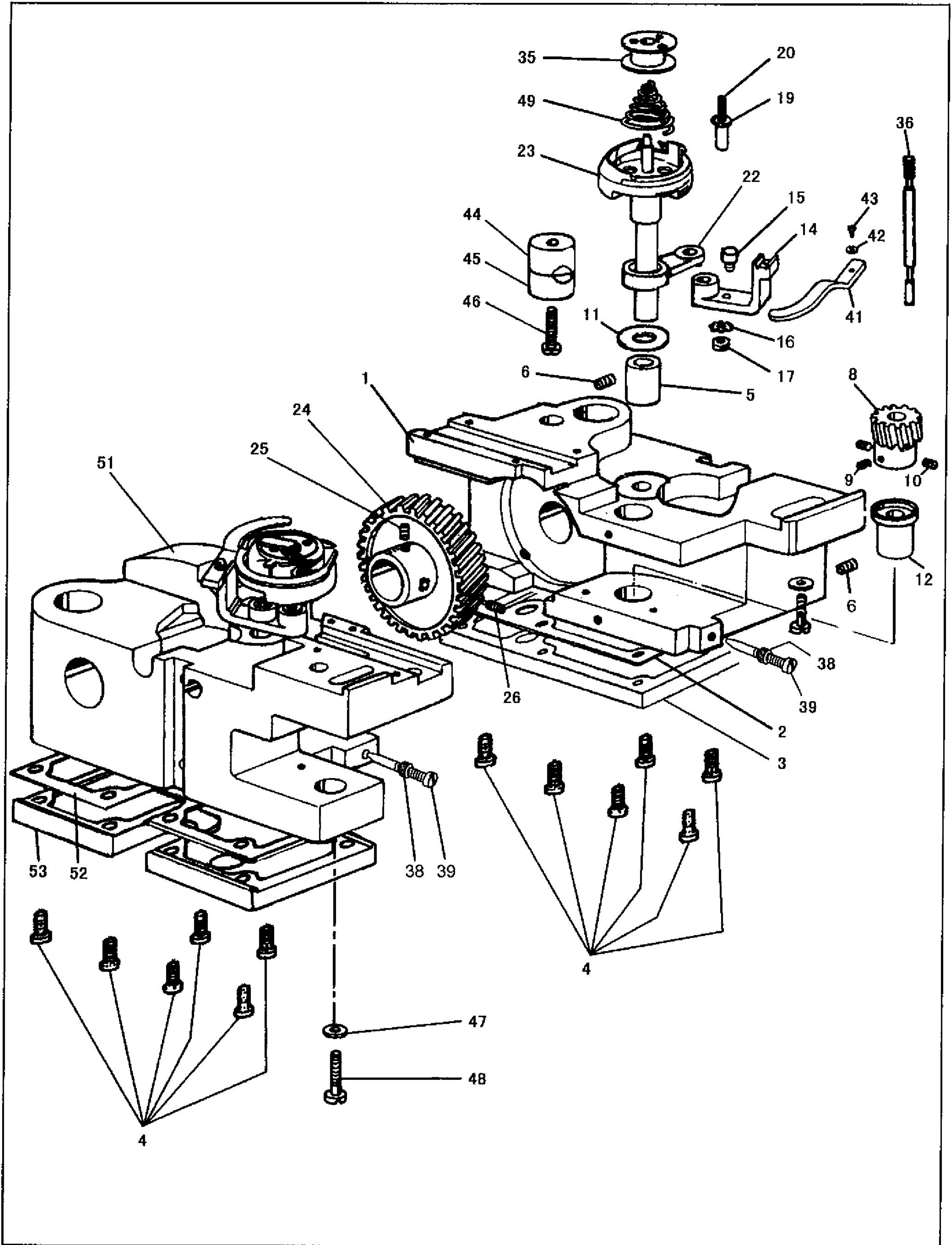

HOOK SADDLE, HOOK

NO	PART NO	255RB-3D	339RB-3D	PARTS NAME
1	HH656J7101	1	1	HOOK SADDLE(RIGHT)
2	HH606J8001	1	1	PACKING
3	HH607J8001	1	1	OIL PRSERVIOR(RIGHT)
4	15007	7	14	SCREW 9/64×40 L=10.0
5	H4909I8001	1	2	BUSHING(UPPER)
6	11176	1	2	SCREW 7/32×32 L=5.5
8	H4705I8001	1	2	HOOK DRIVING PINION(SPIRAL)
9	HA105D0662	1	2	POSITION SCREW 1/4×32 L=5.5
10	H3205H0654	1	2	SET SCREW 1/4×32 L=4.5
11	10644	1	2	WASHER
12	H4911I8001	1	2	BUSHING(LOWER)
13	11176	1	2	SCREW 7/32×32 L=5.5
14	H33131I104	1	2	BOBBIN CASE OPENER LEVER
14	15049	1	2	BOBBIN CASE OPENER LEVER
15	10651	1	2	OPENER LEVER DRIVING SCREW STUD
16	H005008050	1	2	SPRING WASHER
17	10652	1	2	NUT 11/64×40
19	15050	1	2	OPERER LEVER HINGE STUD
20	10727	1	2	FELT
21	10573	1	2	SET SCREW 7/32×32 L=11.0
22	H33131I204	1	2	BOBBIN CASE LEVER LINK
22	15051	1	2	BOBBIN CASE LEVER LINK
23	15040	1	2	HOOK COMPLETE
23	15040	1	2	HOOK COMPLETE
24	H4706I8001	1	2	HOOK DRIVING GFAR
25	H4707I8001	1	2	POSITION SCREW 1/4×40 L=4
26	HA307C0662	2	4	SET SCREW 1/4×40 L=6.5
35	H4908I7101	1	2	BOBBIN
36	15052	1	2	OIL GAUGE
38	H3204I0659	1	2	OIL REGULATING SCREW
39	H3204I0658	1	2	SET SCREW 1/8×40 L=8.0
41	H3305I0066	1	2	BOBBIN CASE LEVER
41	H3305I0066	1	2	BOBBIN CASE LEVER
42	10677	1	2	WASHER
43	10650	1	2	SCREW 3.4×36 L=6.0
44	11145	1	2	PINCH SLEEVE (UPPER)
45	11146	1	2	PINCH SLEEVE (UPPER)
46	11144	1	2	PINCH SLEEVE SCREW 7/32×32 L=32.0
47	10647	1	2	WASHER
48	10646	1	2	SCREW 6.75×24 L=28.0
49			2	SPRING
51	HH705J8001		1	HOOK SADDLE(LEFT)
52	HH707J8001		1	PACKING
53	HH706J8001		1	OIL PRSERVIOR(RIGHT)

KNIFE MECHANISM (1)

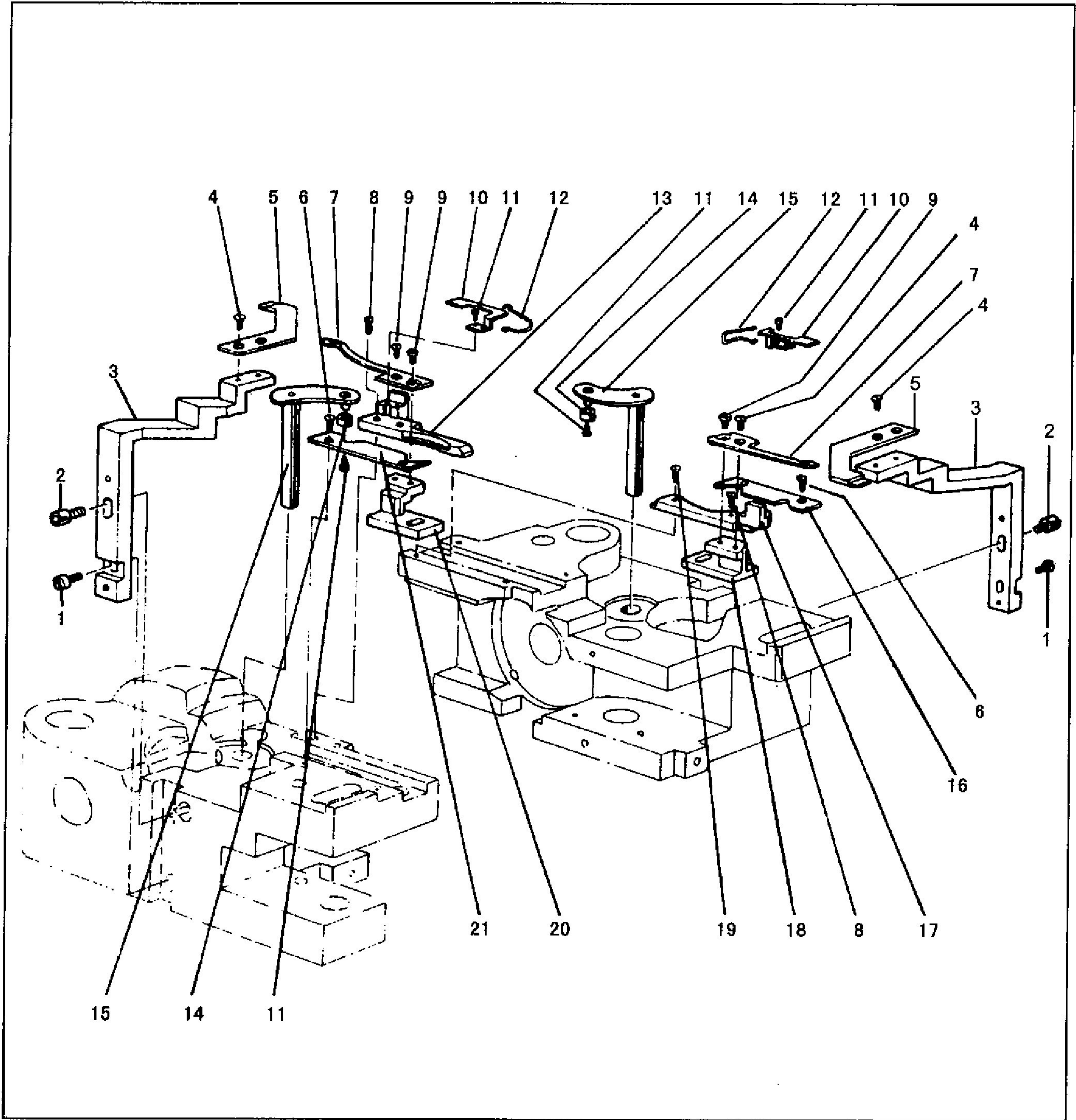

KNIFE MECHANISM (↑)

NO	PART NO	255RB-3D	339RB-3D	PARTS NAME
1	H4905J8001	1	2	SCREW
2	H4906J8001	1	2	Bolt 11/64×40 L=12
3	H4907J8001	1	2	TRIMMING KNIFE HOLDER
4	H4908J8001	3	6	SCREW 9/64×40 L=4
5	H4909J8001	1	2	FIXED BLADE
6	H4914B8001	2	4	SCREW 9/64×40 L=4
7	H4911J8001	1	2	MOVED KNIFE
8	H4912J8001	1	2	SCREW 1/8×44 L=9.2
9	H4913J8001	1	2	SCREW 9/64×40 L=4.5
10	H4914J8001	1	2	SPRING PLATE
11	H4915J8001	3	6	SCREW 3/32×56 L=3.8
12	H4916J8001	1	2	REVERSING SPRING
13	H4919J8001		1	GUIDE
14	H4920J8001	1	2	ROLLER
15	HH605K8001	1	2	LEVER
16	H4922J8001	1	1	COVER
17	H4923J8001	1	1	GUIDER
18	H4924J8001	1	1	KNIFE PAD(RIGHT)
19	H4925J8001	1	1	SCREW 9/64×40 L=9.5
20	H4917J8001		1	KNIFE PAD(LEFT)
21	H4927J8001		1	COVER

KNIFE MECHANISM (II)

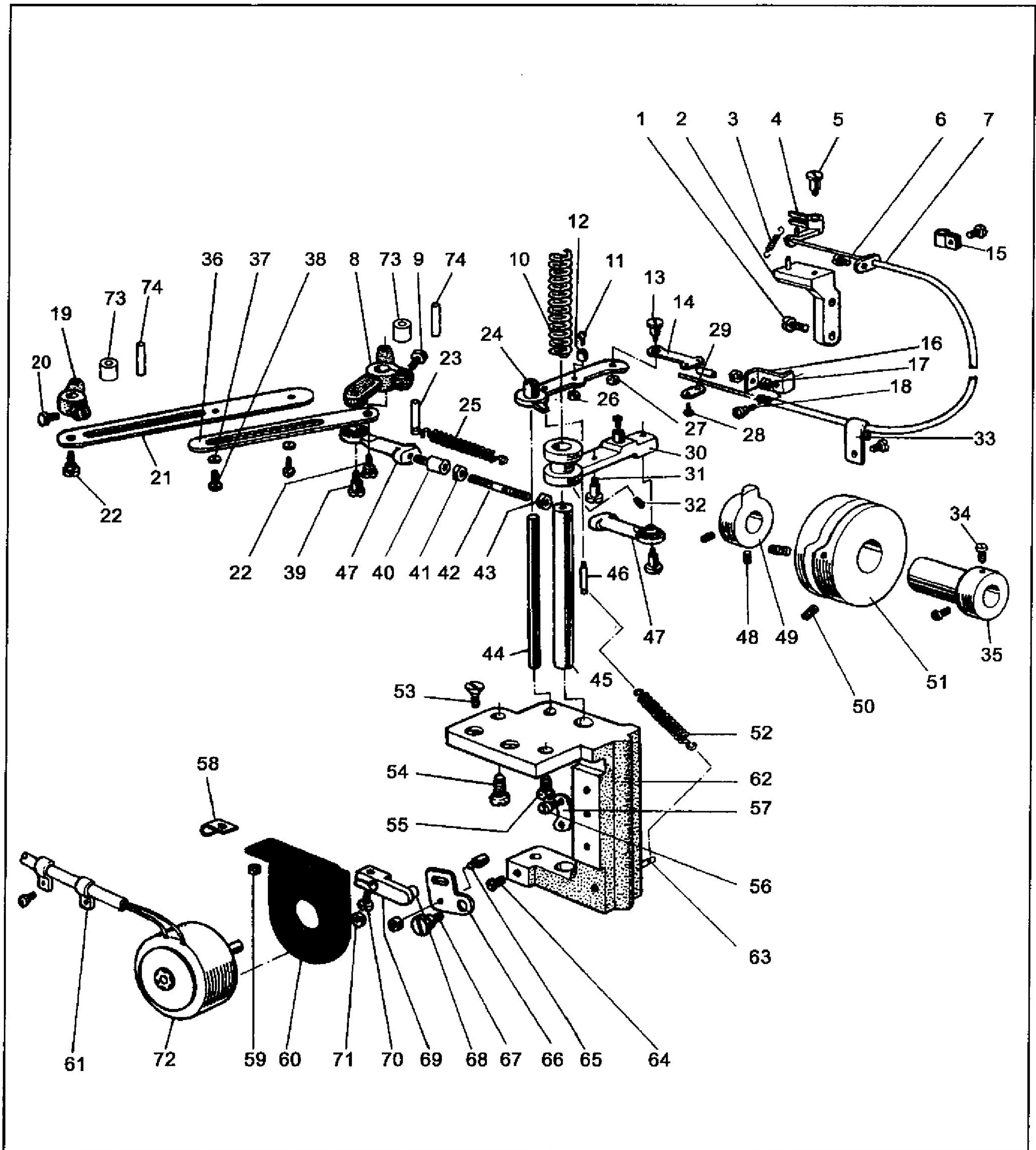

KNIFE MECHANISM (II)

NO	PART NO	255RB-3D	339RB-3D	PARTS NAME
1	HA104G0654	2	2	SCREW SM11/64×40 L=8
2	H4205C0661	1	1	THREAD READING BRACKET
3	H4205C0664	1	1	SPRING
4	H4205C0662	1	1	THREAD READING PLATE
5	H4205C0663	1	1	SCREW SM11/64×40 L=5
6	HA300B2170	4	4	SCREW SM11/64×40 L=8
7	H4923K7101	1	1	FLEXIBLE WIRE COMPLETE
8	H4912K8001	1	1	ARM
9	H4913K8001	1	1	BOLT SM15/64×28 L=12.5
10	H4945K8001	1	1	SPRING
11	H4950K8001	1	1	SCREW SM11/64×40 L=3.6
12	H4949K8001	1	1	ROLLER
13	H4952K8001	1	1	SCREW SM3/16×28 L=5
14	H4953K8001	1	1	MOUNTING PLATE
15	HA700Q0030	1	1	NYLON CLIP
16	H4925K8001	1	1	MOUNTING PLATE
17	H003002050	2	2	NUT M5
18	HA300C2030	1	1	SCREW SM11/64×40 L=7
19	H4908K8001		1	ARM
20	H4907K8001		1	BOLT SM15/64×28L=12.5
21	H4906K8001		1	LINK
22	H4905K8001	2	2	SCREW M5 L=7.5
23	HA100H2080	1	1	PIN TYPE
24	H4946K7101	1	1	THREAD RELEASING LEVER
25	H4943K8001	1	1	SPRING
26	H4951K8001	1	1	NUT SM11/64×40
27	H4954K8001	1	1	NUT SM3/16×28
28	H4956K8001	2	2	SCREW SM1/8×44 L=7
29	H4955K8001	1	1	BUSHING
30	H4957K7101	1	1	VIBRATING CRANK
31	H4944K8001	1	1	SCREW SM11/64×40 L=5.5
32	H431050050	2	2	SCREW M5 L=5
33	HA708P0668	1	1	NYLON CLIP
34	HA113F0684	2	2	SCREW SM15/64×28 L=8.5
35	H4931K8001	1	1	BUSHING
36	H4909K8001		1	LINK
37	H005001050		1	WASHER 5
38	H4911K8001		2	BOLT
39	H4936K8001	2	2	SCREW M5 L=8.5
40	H4987K8001	1	1	BOLT
41	H4940K8001	1	1	NUT (LEFT) M5
42	H4939K8001	1	1	BOLT
43	H003002050	1	1	NUT (RIGHT) M5
44	H4964K8001	1	1	SHAFT
45	H4963K8001	1	1	SHAFT
46	H4985K8001	1	1	SCREW SM11/64×40 L = 4
47	H3405D0663	2	2	BALL JOINT (RIGHT)
48	H3205G1114	4	4	SCREW M4 L = 4
49	H4934K8001	1	1	CAM
50	HA710E0692	2	2	SCREW SM1/4×40 L = 9.5
51	H4932K8001	1	1	CAM
52	H4986K8001	1	1	SPRING
53	H411050160	2	2	SCREW M5 L = 16
54	H2012N0652	1	1	SCREW SM1/4×24 L = 16
55	H4983K8001	1	1	SCREW SM1/4×24 L = 13
56	H4967K8001	3	3	SCREW SM11/64×40 L = 7

KNIFE MECHANISM (II)

NO	PART NO	255RB-3D	339RB-3D	PARTS NAME
57	H4966K8001	1	1	STOPPER
58	H4981K8001	1	1	HOLDER
59	H003008050	2	2	NUT M5
60	H4977K8001	1	1	MOUNTING PLATE
61	H4980K8001	2	2	HOLDER
62	H4965K8001	1	1	SET PLATE
63	H3700E2080	1	1	PIN TYPE
64	H4969K8001	1	1	SCREW SM11/64×40 L = 8.5
65	H4970K8001	1	1	SCREW SM11/64×40 L = 6
66	H4971K8001	1	1	LEVER
67	H4972K8001	1	1	SCREW SM11/64×40 L = 6.8
68	H4973K8001	1	1	PIN
69	H4974K8001	1	1	ARM
70	HA111G0683	1	1	SCREW SM11/64×40 L = 12
71	HA7111N304	1	1	NUT SM11/64×40
72	H4979K8001	1	1	SOLENOID COMPLETE

TOUCH BACK & DETECTOR MECHANISM

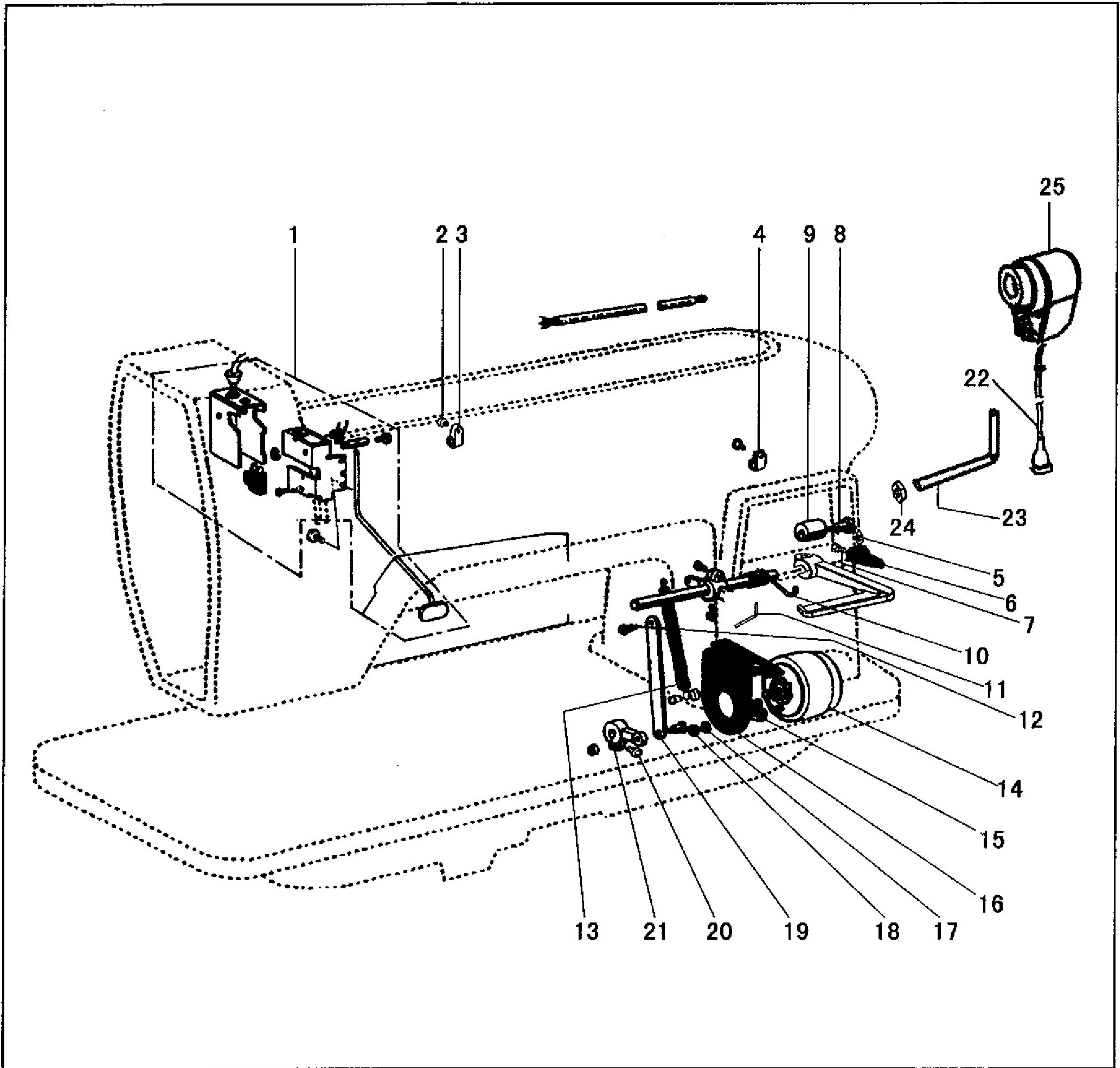

TOUCH BACK & DETECTOR MECHANISM

NO	PART NO	255RB-3D	339RB-3D	PARTS NAME
1	H4905L7101	1	1	TOUTH SWITCH COMPLETE
2	H4918L8001	1	1	SCREW
3	HA700Q0030	1	1	HOLDER
4	H4922L8001	1	1	HOLDER
5	HA3411D308	1	1	SCREW SM15/64×28 L = 7
6	HH606L8001	1	1	LEVER
7	HA113F0684	1	1	SCREW SM15/64×28 L = 7.5
8	H3100G2170	1	1	SCREW SM15/64×28 L = 6
9	HH604L8001	1	1	RUBBER RING
10	H4939L8001	1	1	SPRING
11	H4940L8001	1	1	NUT
12	H4941L8001	1	1	SCREW SM15/64×28 L = 14
13	H4942L8001	1	1	NUT
14	H4943L8001	1	1	SOLENOID (COMPLETE)
15	H102080120	1	1	BLOT M8 L = 12
16	H4945L8001	1	1	SET PLATE
17	H005008060	1	1	SPRING WASHER 6
18	H003002060	1	1	NUT M6
19	H4948L8001	1	1	LINK
20	H4949L8001	1	1	BLOT SM15/64×28 L = 13
21	HH605L8001	1	1	ARM
22	H4952L7101	1	1	SCREW SM11/64×40 L = 8
23	H2600K0020	1	1	SCREW
24	H2600K0030	1	1	NUT M6
25		1	1	SYNCHRONIZER

TENSION

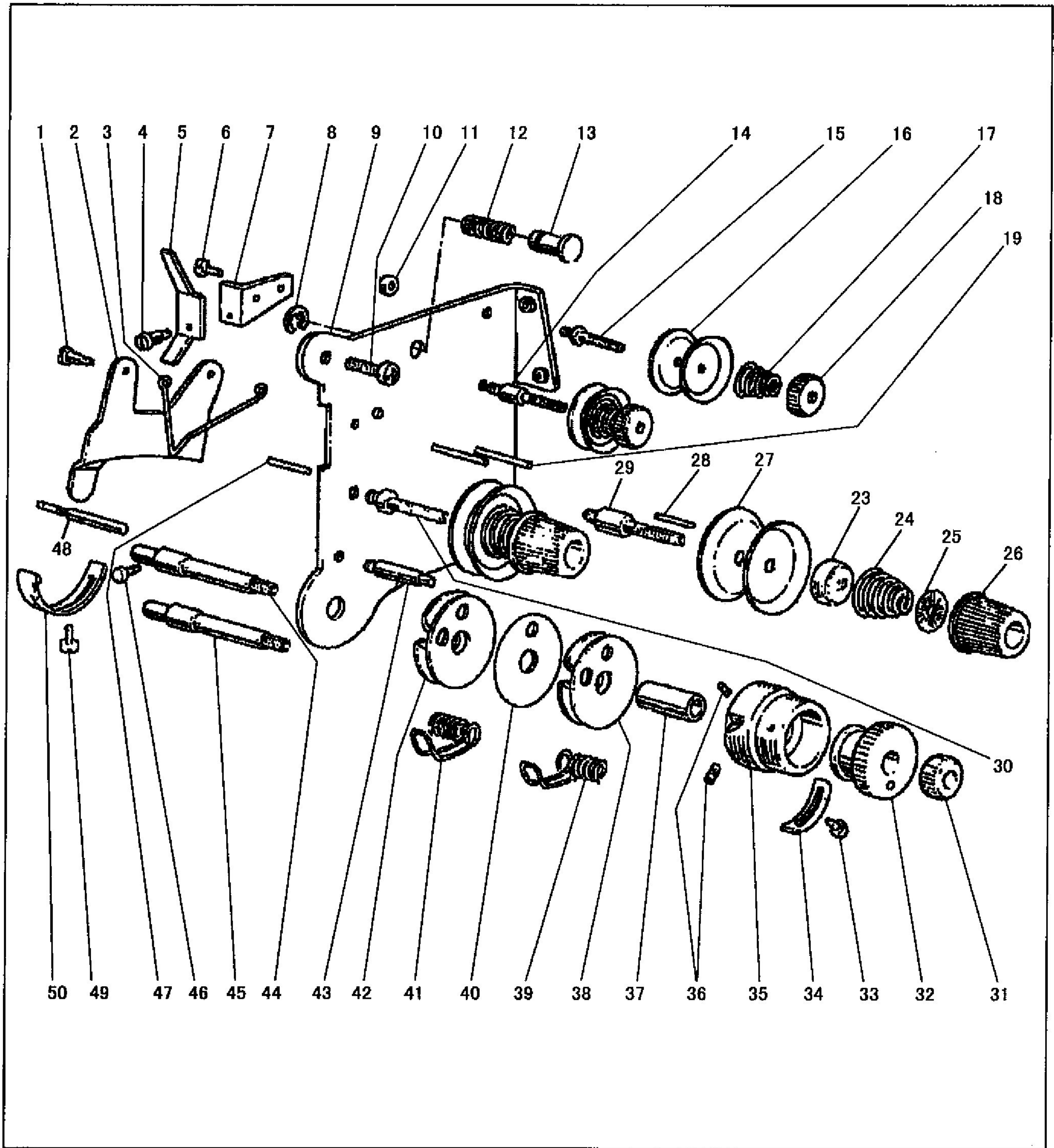

TENSION

NO	PART NO	255RB-3D	339RB-3D	PARTS NAME
1	H3221B6811	2	2	SCREW SM9/64×40 L = 3
2	H3221B3142	1	1	TENSION RELEASING PLATE
3	H3221B6812	1	1	TENSION RELEASING SPRING
4	H4705C8001	1	1	SCREW SM9/64×40 L = 4.2
5	H4706C8001	1	1	LEVER
6	HA7311C306	1	1	SCREW SM9/64×40 L = 4.5
7	H4707C8001	1	1	MOUNTING PLATE
8	H007013050	1	1	STOP RING 5
9	H3221B6820	1	1	MOUNTING PLATE
10	HA300C2030	2	2	SCREW
11	H3221B6810	1	1	NUT SM11/64×40
12	H4708C8001	1	1	SPRING
13	H4709C8001	1	1	PUSH BUTTON
14	H3221B0685		1	THREAD TENSION STUD
15	H3221B0683	1	1	THREAD TENSION STUD
16	HA112B0693	2	4	THREAD TENSION DISK
17	H3221B0684	1	2	THREAD TENSION SPRING
18	HA710B0671	1	2	THUMB NUT
19	H3221B0682	2	3	PIN
23	HA310B0702	1	2	THREAD TENSION RELEASING PLATE
24	H4710C8001	1	2	THREAD TENSION SPRING
25	HA115B7010	1	2	THUMB NUT REVOLUTION STOPPER
26	HA310B0701	1	2	THUMB NUT COMPLETE
27	HA310B0705	2	4	THREAD TENSION DISK
28	H3221B6816		1	PIN
29	H3221B0686		1	THREAD TENSION STUD
30	H3221B0686	1	1	THREAD TENSION STUD
31	H32481B721		1	THUMB NUT SM1/4×40
32	H32481B621		1	TAKE-UP SPRING GUIDE
33	H32481BC21		1	SCREW SM9/64×40 L = 6
34	H32481BB21		1	STOPPER
35	H32481B921		1	THREAD TENSION POST
36	H32481B521		2	SCREW SM1/8 (44) L = 3.9
37	H32481B821		1	BUSHING
38	H32481BD21		1	PLATE COMPLETE
39	H4713C8001		1	THREAD TAKE-UP SPRING
40	H32481BE21		1	PLATE
41	H4713C8001	1	1	THREAD TAKE-UP SPRING
42	H32481BD21	1	1	PLATE COMPLETE
43	H4804C8001	1	1	SCREW
44	H4805C8001		1	THREAD TENSION STUD
45	H4805C8001	1	1	THREAD TENSION STUD
46	H3230K0751	1	1	SCREW SM11/64×40 L = 10
47	H3221B6817	1	1	PIN
48	HH604M8001	1	1	TENSION RELEASING PIN
49	H3200B2100	1	1	SCREW SM9/64×40 L = 6.5
50	H3221B6819	1	1	STOPPER

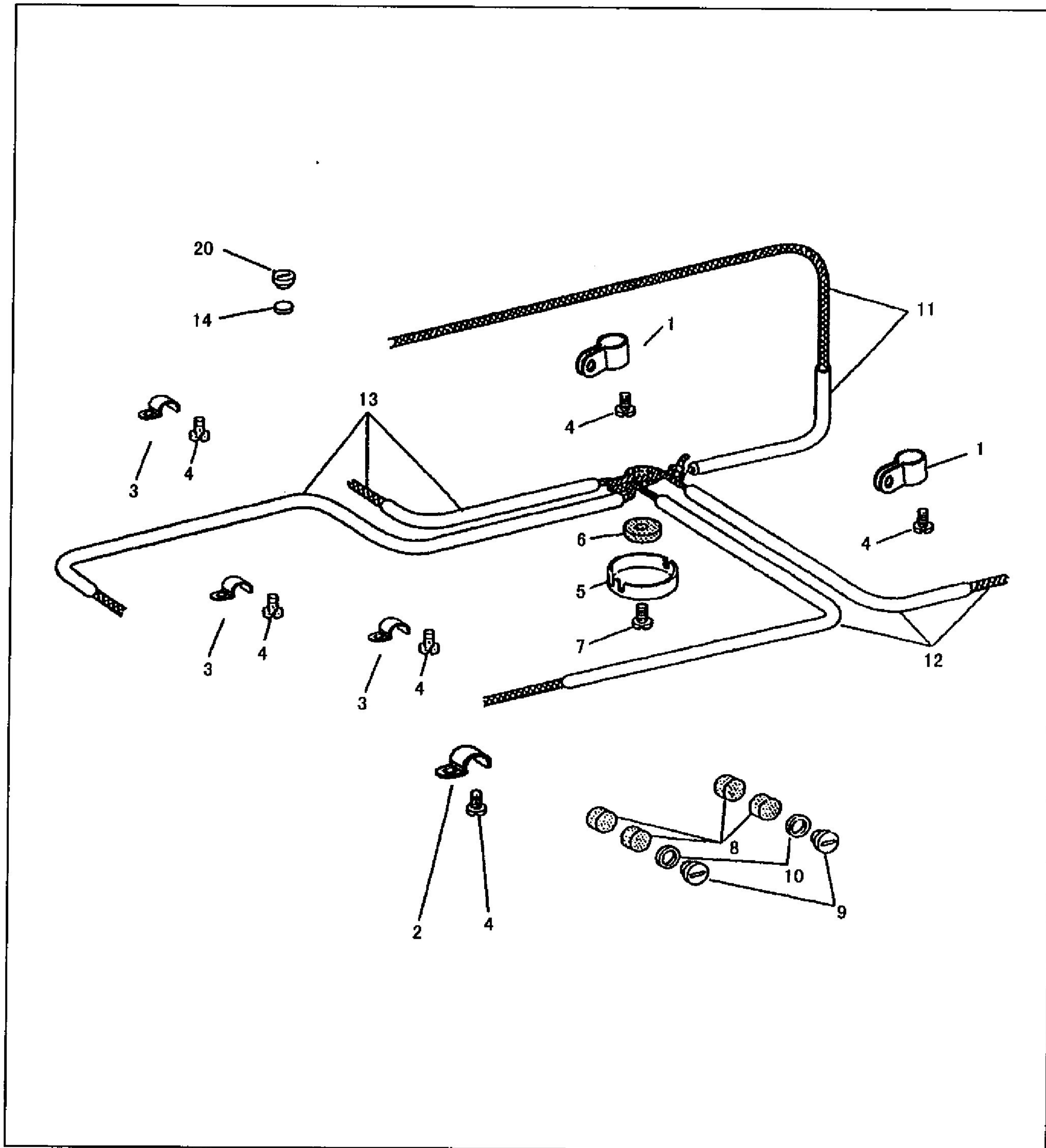

TENSION

NO	PART NO	255RB-3D	399RB-3D	PARTS NAME
1	H6650H8001	2	2	RETAINER
2	H3200K0170	1	1	RETAINER
3	H32311D606	4	4	RETAINER
4	HA300B2130	7	7	SCREW 11/64×40 L=5.5
5	HE606L8001	1	1	BED OIL TUBE CLAMP
6	HE013L8001	1	1	OIL FELT
7	HE014L8001	1	1	SCREW 1/4×32 L=13.0
8	HE016L8001	1	1	OIL FELT
9	HE017L8001	1	1	OIL STOP SCREW 7/16×28
10	HE018L8001	1	1	PACKING
11	HE607L7101	1	1	OIL TUBE AND OIL WICK
12	HE608L7101	1	1	OIL TUBE AND OIL WICK
13	HE610L7101	1	1	OIL TUBE AND OIL WICK
14	HE027L8001	1	1	OIL FELT

ACCESSORIES AND ATTACHMENTS

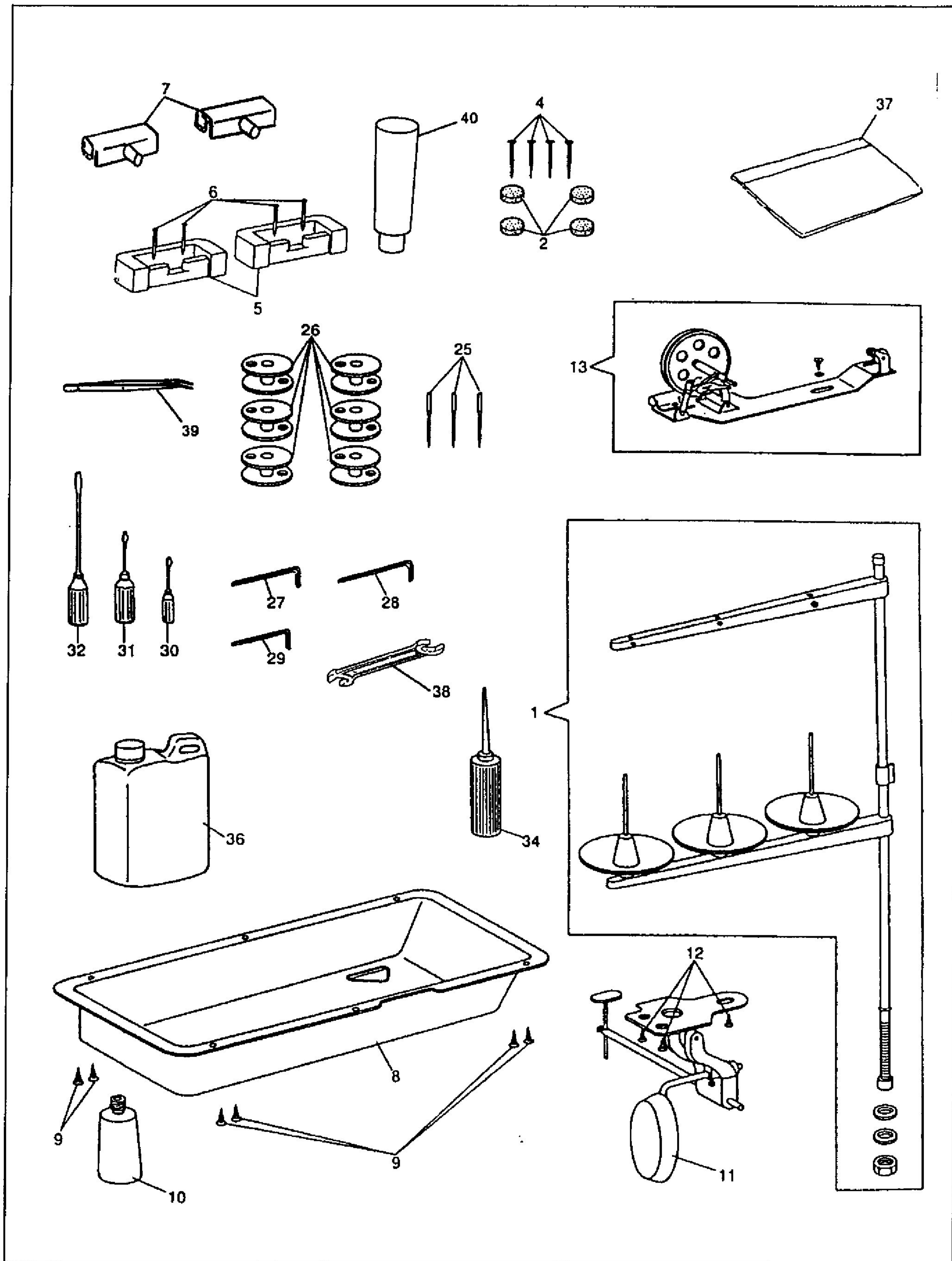

ACCESSORIES AND ATTACHMENTS

NO	PART NO	255RB-3D	339RB-3D	PARTS NAME
1	35254	1	1	THREAD UNWINDER COMPLETE
2	11887	4	4	MACHINE REST
4	6055	4	4	NAIL
5	11886	2	2	MACHIN HINGE CONNECTION CUSHION
6	6055	4	4	NAIL
7	11885	2	2	MACHIN HINGE CONNECTION
8	15080	1	1	DRIP
9	15081	6	6	DRIP PAN NAIL
10	15082	1	1	DRIP PAN DRAIN JAR
11	10735	1	1	KNEE LIFTER COMPLETE
12	6052	3	3	KNEE LIFTER SCREW
13	15101	1	1	BOBBIN WINDER COMPLETE
25	NO122	3	3	NEEDLE
26	15041	4	4	BOBBIN
27	8121	1	1	SCREW DRIVER(SMALL)
28	8120	1	1	SCREW DRIVER(MIDDLE)
29	8118	1	1	SCREW DRIVER(LARGE)
30	10747	1	1	WRENCH
31	11487	1	1	WRENCH
32	11969	1	1	WRENCH
34	8125	1	1	OILER
36	11193	1	1	OIL
37	8132-B	1	1	ACCESSORIES PACK
38	10718	1	1	DOUBLE HEAD WRENCH
39	10730	1	1	CLOTH EDGE GUIDE
40	10731	1	1	SCREW 13/64×32

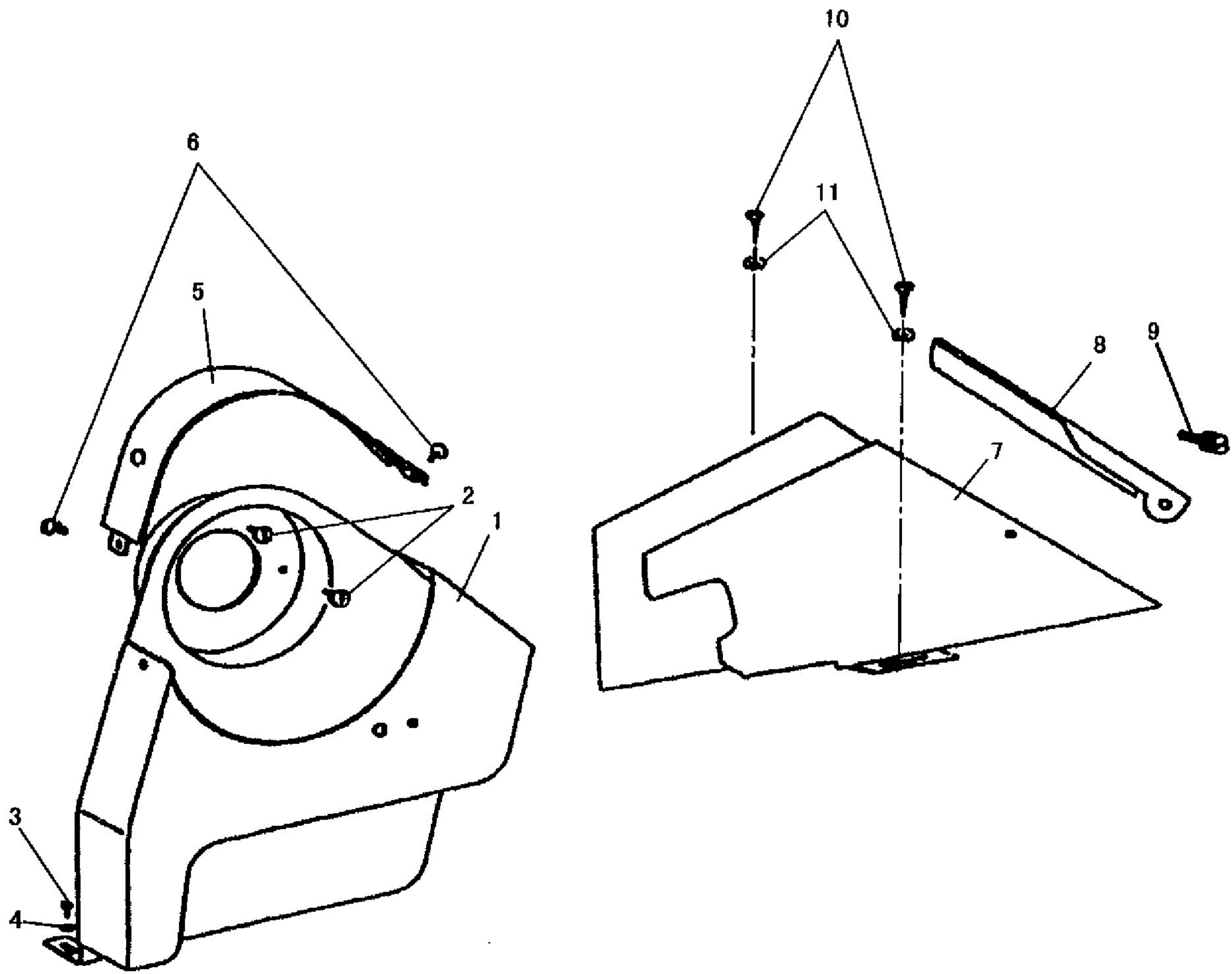

ACCESSORIES AND ATTACHMENTS

NO	PART NO	255RB-3D	399RB-3D	PARTS NAME
1	15098	1	1	BELT GUARD
2	11162	2	2	SCREW 3.4×36 L=5.4
3	10650	1	1	SCREW 3.4×36 L=6.0
4	11142	1	1	WASHER
5	15099	1	1	BELT GUARD (TOP) COVER
6	12418	2	2	SCREW 13/64×32 L=9.0
7	15121	1	1	BELT GUARD (BOTTOM) COVER
8	15122	1	1	BELT GUARD (BOTTOM) COVER (SMALL)
9	11830	1	1	SCREW 9/64×40
10	15081	2	2	SCREW
11	16287	2	2	WASHER
15	10937-01	1	1	FINGER GUARD
16	10749	1	1	SCREW 3.4×36 L=11.0
17	10677	1	1	WASHER

Consolidated Sewing Machine Corp.

website: www.consew.com

MAIN office

131 W. 25th Street
New York, NY 10001
Tel: 212-741-7788
Fax: 212-741-7787
e-mail: consew@att.net

Miami, FL

4013 N.W. 79th St.
Miami, FL 33166
Tel: 305-471-0200
Fax: 305-471-0243
e-mail: miamisales@consew.com

Los Angeles, CA

2320 South Hill Street
Los Angeles, CA 90017
Tel: 213-745-8844
Fax: 213-745-8855
e-mail: lasales@consew.com

Tokyo, Japan

28-16, Nishi-Shinkoiwa 5-Chome
Katsushika-Ku 124-0025
Tokyo, Japan
Tel: 81-3-5698-1639
Fax: 81-3-5698-1626
e-mail: info@consew.jp